

# Electronic housing - UEGM 22,5



2792002

<https://www.phoenixcontact.com/nz/products/2792002>

Please be informed that the data shown in this PDF document is generated from our Online Catalog. Please find the complete data in the user documentation. Our General Terms of Use for Downloads are valid.

Electronic housing, for PCB insertion, fully equipped with 3 screw or 6 tab connections per side



## Commercial Data

Item number	2792002
Packing unit	10 pc
Minimum order quantity	10 pc
Sales Key	ACHCCB
Product Key	ACHCCB
Catalog Page	Page 724 (C-1-2013)
GTIN	4017918072513
Weight per Piece (including packing)	56 g
Weight per Piece (excluding packing)	56 g
Customs tariff number	85389090
Country of origin	DE

## Technical Data

### Product properties

Type	Connection system integrated, housing closed
Product type	Complete housing
Number of positions	6
Pitch	5 mm
Number of rows	1
Type	Complete housing equipped with 3 screw connections per side
Housing type	Component housing
Housing series	UEG
Pin layout	Linear pinning

### Electrical properties

Nominal voltage $U_N$	500 V (Voltage and current values are affected by the configuration of the printed circuit board.)
Nominal current $I_N$	10 A

### Dimensions

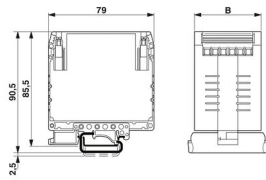
Dimensional drawing	
Width	22.5 mm
Installed height	85.5 mm
Height NS 35/7,5	85.5 mm
Depth	79 mm
Length	79 mm
Pitch	5 mm

### Material specifications

Color	green
Flammability rating according to UL 94	V0
Surface characteristics	untreated
Housing material	Polyamide

### Environmental and real-life conditions

#### Ambient conditions

Degree of protection	IP20
Ambient temperature (operation)	-40 °C ... 105 °C

# Electronic housing - UEGM 22,5

2792002

<https://www.phoenixcontact.com/nz/products/2792002>



## Mounting

Mounting type	DIN rail mounting
Pin layout	Linear pinning

## Drawings

Schematic diagram

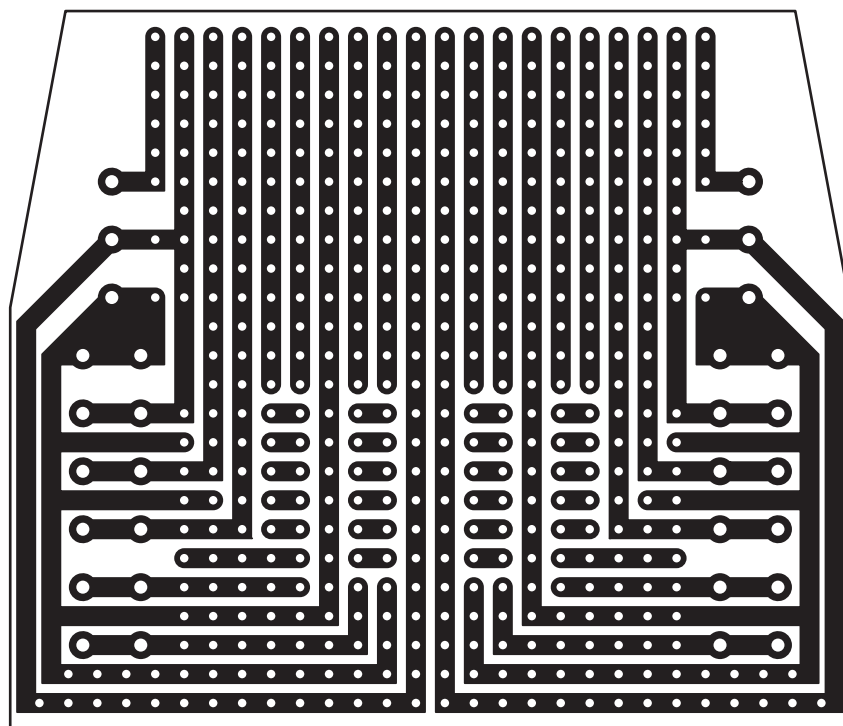

# Electronic housing - UEGM 22,5

2792002

<https://www.phoenixcontact.com/nz/products/2792002>



Dimensional drawing

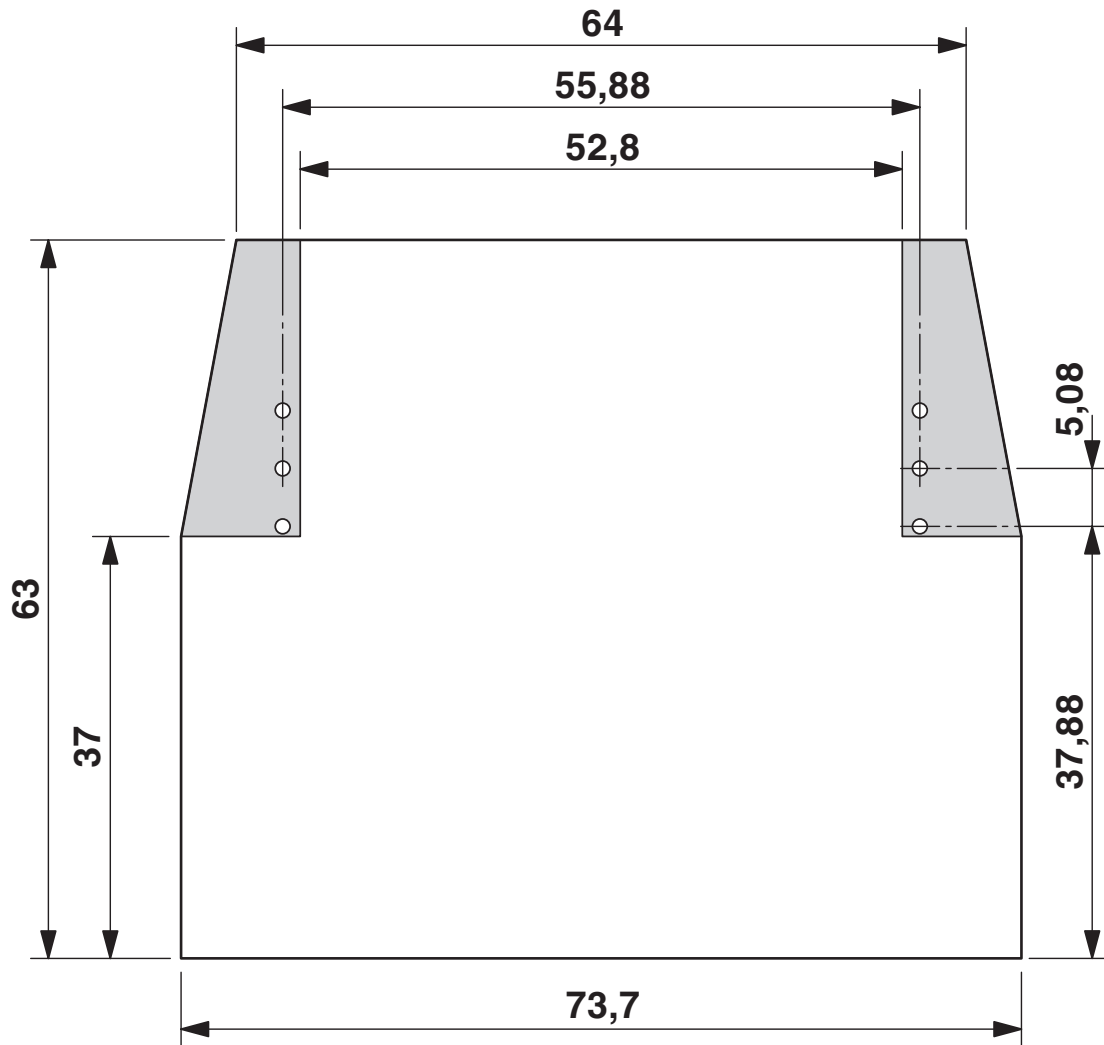

# Electronic housing - UEGM 22,5

2792002

<https://www.phoenixcontact.com/nz/products/2792002>



Dimensional drawing

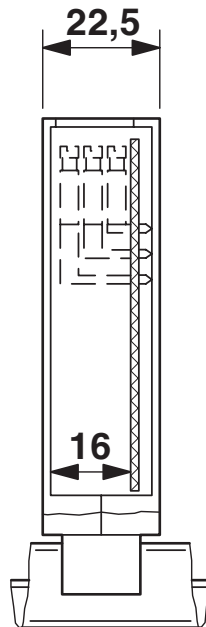

UEGM 22,5... with 1 PCB, 6 positions or 12 positions (FS/FS)

Exploded view

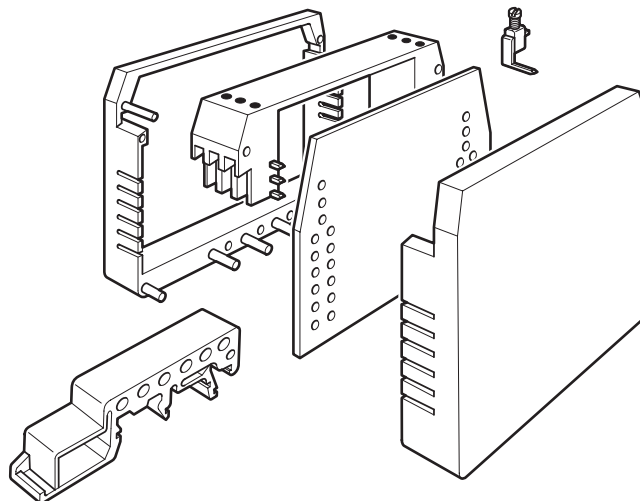

# Electronic housing - UEGM 22,5

2792002

<https://www.phoenixcontact.com/nz/products/2792002>



Dimensional drawing

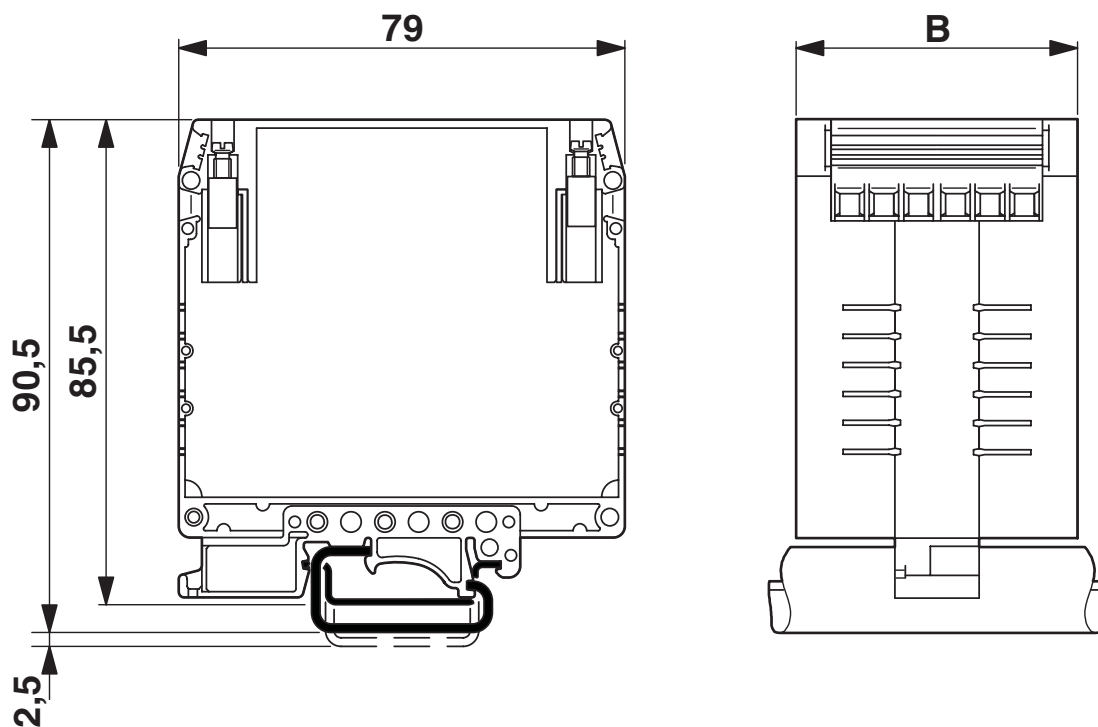

# Electronic housing - UEGM 22,5



2792002

<https://www.phoenixcontact.com/nz/products/2792002>

## Approvals



**EAC**

Approval ID: B.01687



**cULus Recognized**

Approval ID: E60425-19770427

	Nominal Voltage $U_N$	Nominal Current $I_N$	Cross Section AWG	Cross Section $\text{mm}^2$
Use group B				
	300 V	10 A	30 - 12	-
Use group D				
	300 V	10 A	30 - 12	-



# Electronic housing - UEGM 22,5



2792002

<https://www.phoenixcontact.com/nz/products/2792002>

## Classifications

### ECLASS

ECLASS-9.0	27182702
ECLASS-10.0.1	27182702
ECLASS-11.0	27182702

### ETIM

ETIM 8.0	EC001031
----------	----------

### UNSPSC

UNSPSC 21.0	31261500
-------------	----------

# Electronic housing - UEGM 22,5

2792002

<https://www.phoenixcontact.com/nz/products/2792002>



## Environmental Product Compliance

China RoHS	Environmentally Friendly Use Period = 50 years For information on hazardous substances, refer to the manufacturer's declaration available under "Downloads"
------------	--

# Electronic housing - UEGM 22,5

2792002

<https://www.phoenixcontact.com/nz/products/2792002>



## Accessories

### Wire bridge

Wire bridge - DB 50- 90 GY - 2820929

<https://www.phoenixcontact.com/nz/products/2820929>

Flexible wire loop bridge, 50-pos., conductor cross-section: 0.5 mm<sup>2</sup>, loop length: 90 mm, ferrule length: 8 mm, color: gray



---

Phoenix Contact 2022 © - all rights reserved  
<https://www.phoenixcontact.com>

PHOENIX CONTACT Ltd  
Unit 15C, 906-930 Great South Road, Penrose  
Auckland 1061  
0508 474 636  
[sales@phoenixcontact.co.nz](mailto:sales@phoenixcontact.co.nz)