

CAPAROC PM EIP - Power module



1393553

<https://www.phoenixcontact.com/de/produkte/1393553>

Please be informed that the data shown in this PDF document is generated from our online catalog. Please find the complete data in the user documentation. Our general terms of use for downloads are valid.



Power module with EtherNet/IP™ interface for supplying the CAPAROC circuit breaker system with 12 V DC or 24 V DC. Additional system interface for communication with the power supply. For DIN rail installation via the CAPAROC current rails.

Your advantages

- The benchmark that you can customize by selecting single signals and resets all the way to EtherNet/IP™ communication
- Particularly easy operation for everyone with tool-free assembly, direct feed-in to the busbar, and clear operating states
- Exceptionally easy design-in thanks to the comprehensive digital data packet and EtherNet/IP™ function blocks for Studio 5000

Commercial data

Item number	1393553
Packing unit	1 pc
Minimum order quantity	1 pc
Sales key	L1 - Schutzschalter
Product key	CLA231
GTIN	4063151774912
Weight per piece (including packing)	183,5 g
Weight per piece (excluding packing)	147,8 g
Customs tariff number	85363030
Country of origin	DE

Technical data

Notes

General

Note	LABS release – in accordance with test specification VW PV 3. 10.7:2005-0
	When connecting the conductor, make sure that the CAPAROC modules are not pulled apart due to tensile force. Gaps must not be created between the modules.

Product properties

Product type	Device circuit breakers
Product family	CAPAROC
Number of slots	4

Data management status

Article revision	01
------------------	----

Insulation characteristics

Protection class	III
Pollution degree	2

Electrical properties

General

Operating voltage	10 V DC ... 30 V DC
Rated voltage	12 V DC 24 V DC
Rated current I_N	45 A DC (Total current input)
Rated surge voltage	0.5 kV
Tripping method	E (electronic)
Feedback resistance	max. 35 V DC
Dielectric strength	35 V DC (Load circuit)
Efficiency	> 99 %
Closed circuit current I_0	typ. 46 mA (no load at 24 V)
Power dissipation	typ. 1.1 W (no load at 24 V) < 4.5 W (at 40 A)
Temperature derating	45 A (Total current at 60°C) 20 A (Total current at 65 °C) 45 A (Total current at 35°C, in accordance with UL) 40 A (Total current at 40°C, in accordance with UL) 15 A (Total current at 50°C, in accordance with UL)
MTBF (IEC 61709, SN 29500)	7242508.37 h (at 25 °C with 21 % load) 3958056.77 h (at 40°C with 34.25% load) 764697.81 h (at 60°C with 100% load)

CAPAROC PM EIP - Power module



1393553

<https://www.phoenixcontact.com/de/produkte/1393553>

Voltage drop	0.082 V (at 40 A)
Load circuit	
Undervoltage switch-off	≤ 9.2 V DC (active)
	≥ 10.2 V DC (inactive)
Overvoltage switch-off	≥ 30.5 V DC (active)
	≤ 29.5 V DC (inactive)

Connection data

Main circuit IN+

Connection method	Push-in connection
Stripping length	18 mm
Conductor cross section AWG	20 ... 8
Conductor cross section, flexible, with ferrule, with plastic sleeve	0.5 mm ² ... 16 mm ²
Conductor cross section flexible, with ferrule without plastic sleeve	0.5 mm ² ... 16 mm ²

Main circuit IN-

Connection method	Push-in connection
Stripping length	18 mm
Conductor cross section AWG	20 ... 8
Conductor cross section, flexible, with ferrule, with plastic sleeve	0.5 mm ² ... 16 mm ²
Conductor cross section flexible, with ferrule without plastic sleeve	0.5 mm ² ... 16 mm ²

System communication

Connection method	Push-in connection
Stripping length	8 mm
Conductor cross section rigid	0.2 mm ² ... 1.5 mm ²
Conductor cross section AWG	24 ... 16
Conductor cross section, flexible, with ferrule, with plastic sleeve	0.2 mm ² ... 0.75 mm ²
Conductor cross section flexible, with ferrule without plastic sleeve	0.2 mm ² ... 1.5 mm ²

Interfaces

EtherNet/IP™

Maximum system extension	≤ 16 (CAPAROC modules alignable)
Interface type	Ethernet
Number	2
Transmission speed	10 Mbps 100 Mbps
Transmission physics	Ethernet in RJ45 twisted pair
Protocols supported	EtherNet/IP™

Signaling

Connection X1 LED green	lit (connect)
Connection X1 LED yellow	lit (traffic)

CAPAROC PM EIP - Power module



1393553

<https://www.phoenixcontact.com/de/produkte/1393553>

Connection X2 LED green	lit (connect)
Connection X2 LED yellow	lit (traffic)
Power (PWR) LED green	lit (Supply voltage within the operating voltage range) 3x flashing (Global programming lock deactivated)
Power (PWR) LED red	lit (Supply voltage outside the operating voltage range) 5x flashing (Factory reset command accepted)
Power (PWR) LED yellow	lit (PWR button pressed) 3x flashing (Global programming lock activated)
NET LED off	off (No voltage present at the device or no IP address configured)
NET LED green	lit (Communication with the controller present) flashing (IP address available, no communication with the controller)
NET LED red	lit (Address Conflict Detection (ACD): "Duplicate IP." Device has detected that its IP address is already in use in the network.)
NET LED red-green	flashing (Device initialization self-test)
MOD LED off	off (No supply voltage)
MOD LED green	lit (Normal operation) flashing (The device is not yet configured)
MOD LED red-green	flashing (Device initialization self-test)
MOD LED red	lit (Error (EtherNet/IP™: "Major unrecoverable fault"), e.g., program crash in the controller) flashing (Error (EtherNet/IP™: "Major recoverable fault"), e.g., inconsistent or incorrect parameterization)
Ready (RDY) LED yellow-green	flashing (Firmware installation running)
Ready (RDY) LED yellow	lit (Firmware installation failed, perform manual voltage reset)
Ready (RDY) LED green	lit (Firmware started successfully)

Dimensions

Dimensional drawing	
Width	24.8 mm
Height	132.4 mm
Depth	111.3 mm (incl. DIN rail 7.5 mm)

Material specifications

Color	light gray (RAL 7035)
Material	PA 6 PA 6 PA 6 PC

CAPAROC PM EIP - Power module



1393553

<https://www.phoenixcontact.com/de/produkte/1393553>

Flammability rating according to UL 94	V-0
--	-----

Environmental and real-life conditions

Ambient conditions

Degree of protection	IP20
Ambient temperature (operation)	-30 °C ... 65 °C
Ambient temperature (storage/transport)	-40 °C ... 70 °C
Altitude	≤ 4000 m (amsl)
Humidity test	96 h, 95 % RH, 40 °C
Shock (operation)	30g (11 ms period, half-sine shock pulse, according to IEC 60068-2-27) 25g (6 ms duration, half-sine shock pulse in accordance with IEC 60068-2-27, continuous shock)
Vibration (operation)	5g (10 ... 150 Hz / 10 cycles / axis / X, Y, Z)

Approvals

UL approval

Identification	UL/C-UL Listed UL 508 UL 121201 Class I, Division 2, Groups A, B, C, D, T4A
----------------	--

Standards and regulations

Standards/specifications	EN 61000-6-2
Note	EMC – Immunity for industrial areas
Standards/specifications	EN 61000-6-4
Note	EMC – Immunity for industrial areas
Standards/specifications	EN 61000-6-8
Note	EMC interference emission for professional devices that are used in business and commercial areas as well as in small businesses
Standards/specifications	EN 60068-2-78
Note	Environmental influences – Moisture and heat, constant
Standards/specifications	EN 50178
Note	Equipping power installations with electronic equipment
Standards/specifications	EN 60068-2-6
Note	Environmental influences – Vibrations (sinusoidal)
Standards/specifications	EN 60068-2-27
Note	Environmental influences – Shocks

Mounting

Mounting type	pluggable onto CAPAROC CR... current rail
---------------	---

CAPAROC PM EIP - Power module



1393553

<https://www.phoenixcontact.com/de/produkte/1393553>

Drawings

Dimensional drawing

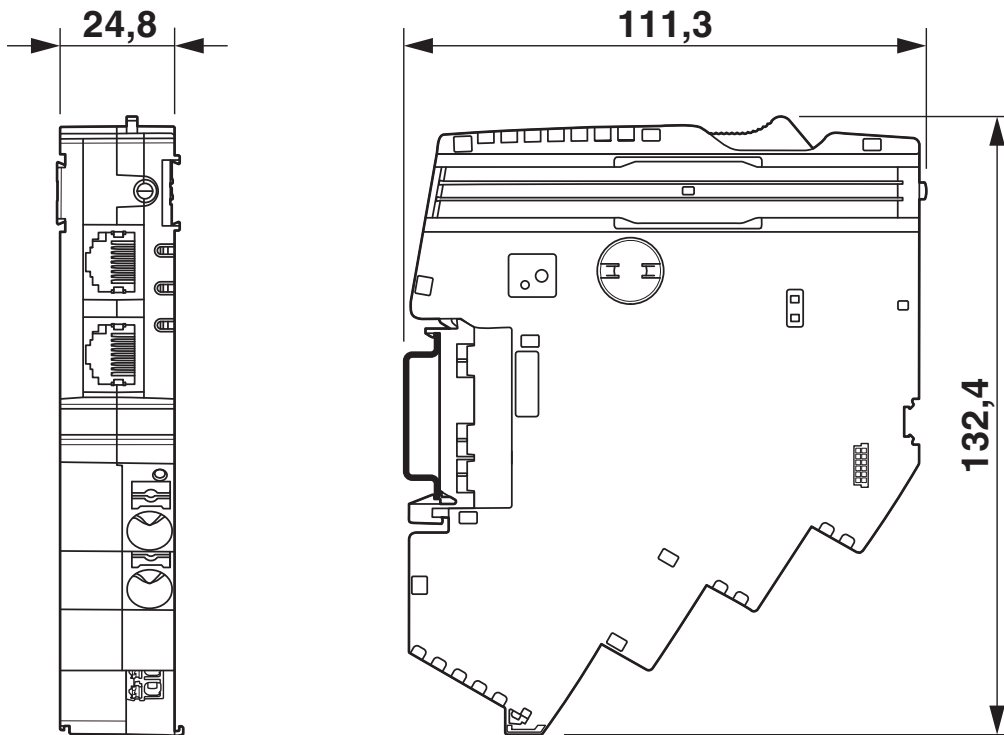

CAPAROC PM EIP - Power module

1393553

<https://www.phoenixcontact.com/de/produkte/1393553>



Product drawing

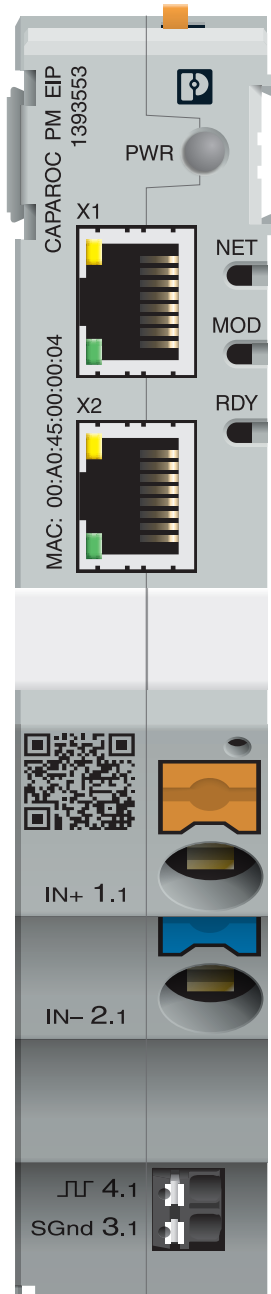

CAPAROC PM EIP - Power module

1393553

<https://www.phoenixcontact.com/de/produkte/1393553>

Schematic diagram

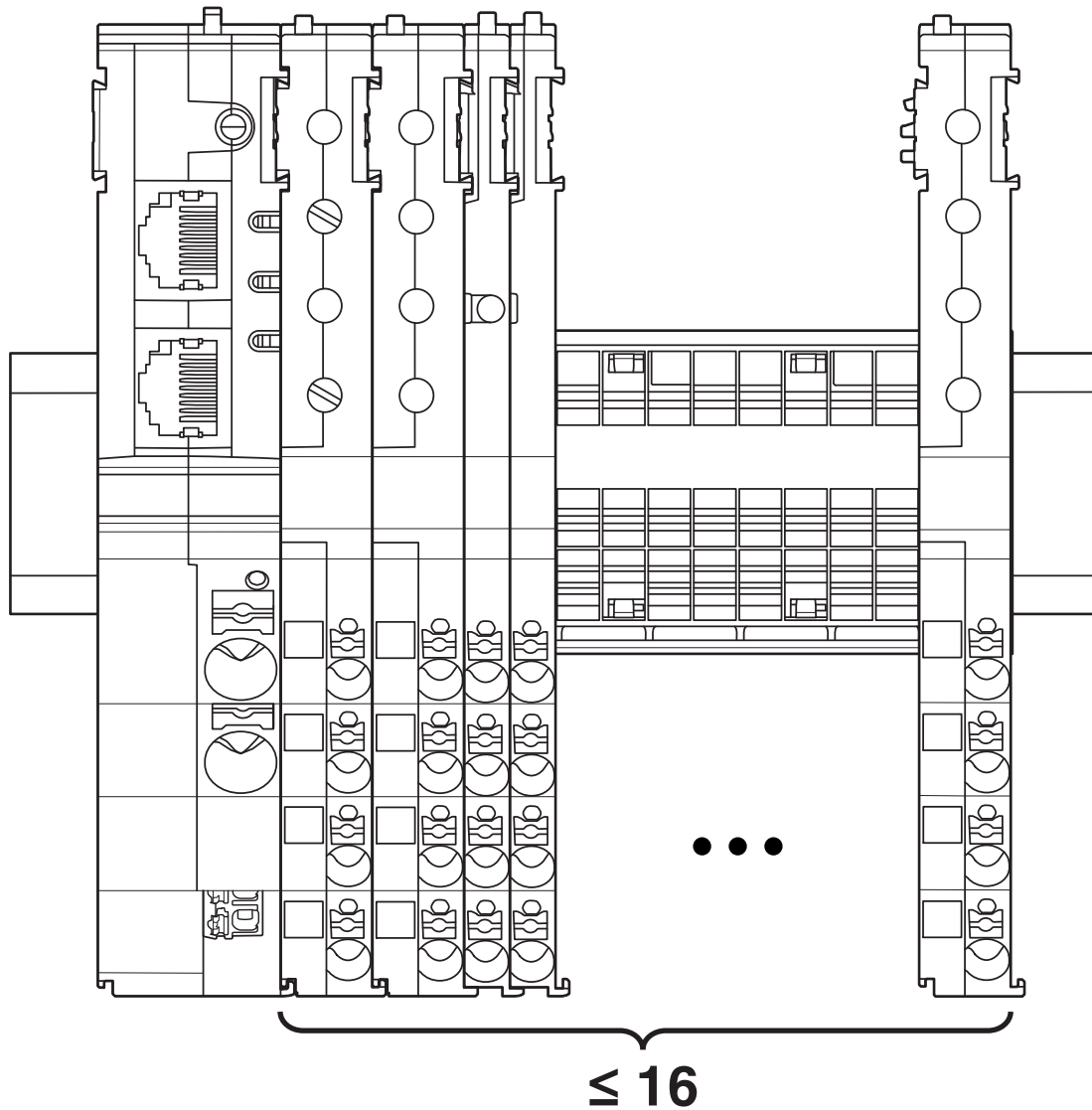

When using the power module with an EtherNet/IP™ interface (CAPAROC PM EIP), max. 16 circuit breaker modules can be set. Any number of extra potential distribution modules can be added.

Block diagram

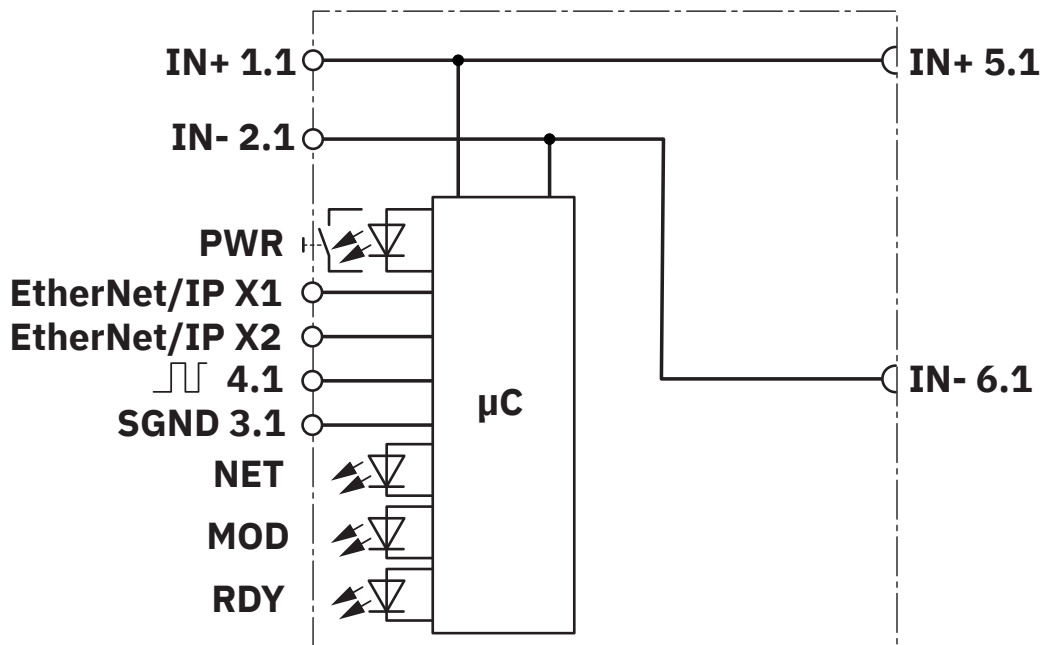

Diagram

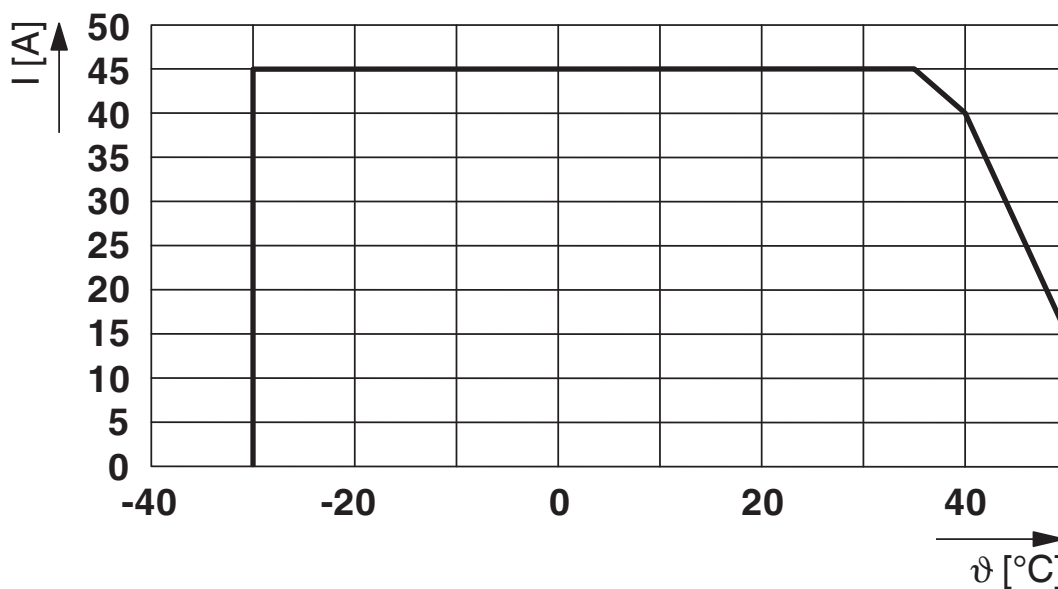

Max. permissible current depending on the ambient temperature for continuous loads > 8 A per channel

CAPAROC PM EIP - Power module



1393553

<https://www.phoenixcontact.com/de/produkte/1393553>

Approvals

To download certificates, visit the product detail page: <https://www.phoenixcontact.com/de/produkte/1393553>

 **UL Listed**
Approval ID: E123528

 **cUL Listed**
Approval ID: E123528

EtherNet/IP CONFORMANCE TESTED TM
Approval ID: 12382.01

 **cUL Listed**
Approval ID: E483407

 **UL Listed**
Approval ID: E483407

cULus Listed

cULus Listed

CAPAROC PM EIP - Power module



1393553

<https://www.phoenixcontact.com/de/produkte/1393553>

Classifications

ECLASS

ECLASS-11.0	27140401
ECLASS-12.0	27140401
ECLASS-13.0	27140401

ETIM

ETIM 8.0	EC003538
----------	----------

CAPAROC PM EIP - Power module



1393553

<https://www.phoenixcontact.com/de/produkte/1393553>

Environmental product compliance

EU RoHS

Fulfills EU RoHS substance requirements	Yes
Exemption	7(a), 7(c)-I

China RoHS

Environment friendly use period (EFUP)	EFUP-50
	An article-related China RoHS declaration table can be found in the download area for the respective article under "Manufacturer declaration". For all articles with EFUP-E, no China RoHS declaration table issued and required.

EU REACH SVHC

REACH candidate substance (CAS No.)	Lead(CAS: 7439-92-1)
-------------------------------------	----------------------

CAPAROC PM EIP - Power module



1393553

<https://www.phoenixcontact.com/de/produkte/1393553>

Mandatory accessories

CAPAROC CR 20 - Busbar

1110989

<https://www.phoenixcontact.com/de/produkte/1110989>

Busbar for CAPAROC system with 20 slots. For installation on a DIN rail.



CAPAROC CR 8 - Busbar

1115672

<https://www.phoenixcontact.com/de/produkte/1115672>

Busbar for the CAPAROC system with 8 slots. For installation on a DIN rail.



Accessories

CAPAROC PM EIP - Power module

1393553

<https://www.phoenixcontact.com/de/produkte/1393553>



CAPAROC E1 12-24DC/1-4A - Electronic circuit breaker

1115415

<https://www.phoenixcontact.com/de/produkte/1115415>



1-channel electronic circuit breaker module for protecting 12 and 24 V DC loads against overload and short circuit. Nominal current adjustable from 1 A to 4 A via LED button. For DIN rail installation via the CAPAROC current rails.

CAPAROC E1 12-24DC/1-10A - Electronic circuit breaker

1115649

<https://www.phoenixcontact.com/de/produkte/1115649>



1-channel electronic circuit breaker module for protecting 12 and 24 V DC loads against overload and short circuit. Nominal current adjustable from 1 A to 10 A via LED button. For DIN rail installation via the CAPAROC current rails.

CAPAROC PM EIP - Power module

1393553

<https://www.phoenixcontact.com/de/produkte/1393553>



CAPAROC E1 12-24DC/1A - Electronic circuit breaker

1157288

<https://www.phoenixcontact.com/de/produkte/1157288>



1-channel electronic circuit breaker module for protecting 12 and 24 V DC loads against overload and short circuit. With fixed nominal current. For DIN rail installation via the CAPAROC current rails.

CAPAROC E1 12-24DC/2A - Electronic circuit breaker

1157290

<https://www.phoenixcontact.com/de/produkte/1157290>



1-channel electronic circuit breaker module for protecting 12 and 24 V DC loads against overload and short circuit. With fixed nominal current. For DIN rail installation via the CAPAROC current rails.

CAPAROC PM EIP - Power module

1393553

<https://www.phoenixcontact.com/de/produkte/1393553>



CAPAROC E1 12-24DC/4A - Electronic circuit breaker

1157285

<https://www.phoenixcontact.com/de/produkte/1157285>



1-channel electronic circuit breaker module for protecting 12 and 24 V DC loads against overload and short circuit. With fixed nominal current. For DIN rail installation via the CAPAROC current rails.

CAPAROC E1 12-24DC/6A - Electronic circuit breaker

1157286

<https://www.phoenixcontact.com/de/produkte/1157286>



1-channel electronic circuit breaker module for protecting 12 and 24 V DC loads against overload and short circuit. With fixed nominal current. For DIN rail installation via the CAPAROC current rails.

CAPAROC PM EIP - Power module

1393553

<https://www.phoenixcontact.com/de/produkte/1393553>



CAPAROC E1 12-24DC/8A - Electronic circuit breaker

1157279

<https://www.phoenixcontact.com/de/produkte/1157279>



1-channel electronic circuit breaker module for protecting 12 and 24 V DC loads against overload and short circuit. With fixed nominal current. For DIN rail installation via the CAPAROC current rails.

CAPAROC E1 12-24DC/10A - Electronic circuit breaker

1157284

<https://www.phoenixcontact.com/de/produkte/1157284>



1-channel electronic circuit breaker module for protecting 12 and 24 V DC loads against overload and short circuit. With fixed nominal current. For DIN rail installation via the CAPAROC current rails.

CAPAROC PM EIP - Power module

1393553

<https://www.phoenixcontact.com/de/produkte/1393553>



CAPAROC E2 12-24DC/1-4A - Electronic circuit breaker

1115655

<https://www.phoenixcontact.com/de/produkte/1115655>



2-channel electronic circuit breaker module for protecting loads at 12 and 24 V DC against overload and short circuit with current limit. Nominal current adjustable from 1 A to 4 A using step switch. For DIN rail installation via the CAPAROC current rails.

CAPAROC E2 12-24DC/2-10A - Electronic circuit breaker

1110984

<https://www.phoenixcontact.com/de/produkte/1110984>



2-channel electronic circuit breaker module for protecting loads at 12 and 24 V DC against overload and short circuit with current limit. Nominal current adjustable from 2 A to 10 A using step switch. For DIN rail installation via the CAPAROC current rails.

CAPAROC PM EIP - Power module

1393553

<https://www.phoenixcontact.com/de/produkte/1393553>



CAPAROC E4 12-24DC/1-4A - Electronic circuit breaker

1115657

<https://www.phoenixcontact.com/de/produkte/1115657>



Four-channel electronic circuit breaker module for protecting 12 and 24 V DC loads against overload and short circuit. Nominal current adjustable from 1 A to 4 A via LED button. For DIN rail installation via the CAPAROC current rails.

CAPAROC E4 12-24DC/1-10A - Electronic circuit breaker

1115658

<https://www.phoenixcontact.com/de/produkte/1115658>



Four-channel electronic circuit breaker module for protecting 12 and 24 V DC loads against overload and short circuit. Nominal current adjustable from 1 A to 10 A via LED button. For DIN rail installation via the CAPAROC current rails.

CAPAROC PM EIP - Power module

1393553

<https://www.phoenixcontact.com/de/produkte/1393553>



CAPAROC PD 0V - Potential distributors

1110987

<https://www.phoenixcontact.com/de/produkte/1110987>



Potential distributor with Push-in connections for directly connecting the 0 V return conductor in the CAPAROC system. For DIN rail installation via the CAPAROC current rails.

USB IO-LINK ADAPTER - Programming adapter

1533311

<https://www.phoenixcontact.com/de/produkte/1533311>



IO-Link programming adapter for the USB interface, for configuring IO-Link-capable products with compatible Phoenix Contact software.

1393553

<https://www.phoenixcontact.com/de/produkte/1393553>

UC-TM 12 - Marker for terminal blocks

0819194

<https://www.phoenixcontact.com/de/produkte/0819194>



Marker for terminal blocks, Sheet, white, unlabeled, can be labeled with: BLUEMARK ID COLOR, BLUEMARK ID, BLUEMARK CLED, PLOTMARK, CMS-P1-PLOTTER, mounting type: snapped, for terminal block width: 12 mm, lettering field size: 11.45 x 10.5 mm, Number of individual labels: 40

UCT-TM 12 - Marker for terminal blocks

0829144

<https://www.phoenixcontact.com/de/produkte/0829144>



Marker for terminal blocks, Sheet, white, unlabeled, can be labeled with: TOPMARK NEO, TOPMARK LASER, BLUEMARK ID COLOR, BLUEMARK ID, BLUEMARK CLED, THERMOMARK PRIME, THERMOMARK CARD 2.0, THERMOMARK CARD, mounting type: snapped, for terminal block width: 12 mm, lettering field size: 10.8 x 9.6 mm, Number of individual labels: 30

CAPAROC PM EIP - Power module

1393553

<https://www.phoenixcontact.com/de/produkte/1393553>



CAPAROC CR EXT20 - Busbar

1115674

<https://www.phoenixcontact.com/de/produkte/1115674>

Extension busbar with 20 slots for the CAPAROC system. For installation on a DIN rail.



CAPAROC CR EXT8 - Busbar

1110990

<https://www.phoenixcontact.com/de/produkte/1110990>

Extension busbar with 8 slots for CAPAROC system. For installation on a DIN rail.



CAPAROC PM EIP - Power module

1393553

<https://www.phoenixcontact.com/de/produkte/1393553>



CAPAROC CR EXT4 - Busbar

1110991

<https://www.phoenixcontact.com/de/produkte/1110991>



Extension busbar with 4 slots for the CAPAROC system. For installation on a DIN rail.

CAPAROC CR CON - Metal part

1270955

<https://www.phoenixcontact.com/de/produkte/1270955>



Metal extension rails from connecting CAPAROC initial busbars.

Phoenix Contact 2024 © - all rights reserved
<https://www.phoenixcontact.com>

PHOENIX CONTACT Deutschland GmbH
Flachsmarktstraße 8
D-32825 Blomberg
+49 52 35/3-1 20 00
info@phoenixcontact.de